

Vibration-Assisted ball burnishing. A solution for Surface enhancement through acoustoplasticity

An innovative system to modify the surface integrity, i.e. surface texture and roughness, hardness and residual stress, of previously milled workpieces has been developed. The system can be easily integrated in real manufacturing environments, but should be tested with that aim. Partners to further develop the system and/or to establish commercial agreements along with technical cooperation are sought.

The Challenge

The manufacturing industry demands effective finishing processes to which workpieces could be subjected to enhance their future in-service performance. This need is especially required for innovative materials, as they usually show a detrimental surface integrity state due to their low machinability. In the transportation industry, the manufacturing of components such as turbine blades, requires the application of local processes that could reinforce critical areas of the workpiece that are subjected to demanding regimes, such as fatigue. Improving the surface and near-surface texture, roughness, residual stress and hardness is a mean to prevent crack growth and enhance the behavior of these components. In this context, the vibration-assisted ball burnishing tool has proved positive results in laboratory applications, and is ready for a leap forward into the industry,

The Technology

The system consists of a ball burnishing tool with a force regulation system based on a calibrated spring compression. It is equipped with a stacked piezoelectric module that, linked to the burnishing ball support, transmits a 40 kHz ultrasonic vibratory movement to the ball as it rolls over the target surface. The piezoelectric is excited through an external power circuit detached from the manufacturing environment. The oscillatory force allows to take advantage of the acoustoplastic effect, that is, the instantaneous decrease of the stress required to cause plastic strain while leaving residual hardening on the material. The tool is prepared to be mounted on a milling machine through

Innovative advantages

- Competitive effects compared to those obtained through conventional finishing process such as polishing, or shot peening
- Easiness of automatization and implementation in workshops
- As the process is chipless, no residual substances or materials are generated
- Inexpensive system with low maintenance costs

Current stage of development

The prototype has been tested on ball-end milled AISI 1038, Ti6Al4V and Al 2017 surfaces, proving its beneficial effects in terms of texture, roughness, hardness, and residual stress.

Applications and Target Market

The preferential market for this system is related to manufacturing centers in the transportation industry, as they work on pieces that are obtained by milling operations and require the application of finishing operations to enhance their surface finish state. The finishing of manufacturing equipment, such as molds or dies, is also a target area of the technology. In fact, it can be adapted to any application that could eventually require of local hardening effects, which can be easily delivered through the technique.

Reference number

MKT2018/0163_G

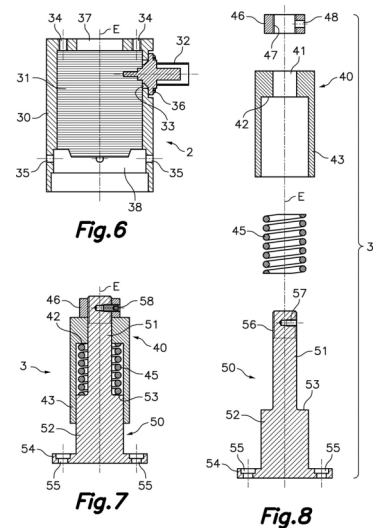

Vibration-assisted ball burnishing system



Enhanced roughness, texture, hardness and residual stress on ball-end milled surfaces.

Business Opportunity

Technology available for licensing with technical cooperation

Patent Status

Priority application - PCT

Contact

Mr. Gerard Margalef Martínez
Licensing Manager
T. + 34 934 137 627
M. +34 666 547 787
gerard.margalef@upc.edu

See more technologies at

www.upc.edu/patents
UPC—BarcelonaTech