

SAFETY AND HYGIENE REGULATIONS



Servei de Prevenció de Riscos Laborals
UNIVERSITAT POLITÈCNICA DE CATALUNYA

HAND PALLET TRUCKS

CODE

SHR 212

Date:

July 2003

Revision:

00

Page:

1 of 3

DESCRIPTION OF A HAND PALLET TRUCK

1. A hand pallet truck is comprised of a cold-bent, welded and machined metal chassis.
2. At the front is a tiller arm that is used to steer the pallet truck and to operate the lifting mechanism. The chassis of the forks can be raised above ground level using a small hydraulic pump that is operated manually.
3. The control lever for the hydraulic system has three positions to lift the forks, lower them or put them in a neutral, resting position.
4. The part of the machine that is comprised of the hydraulic pump, the joint of the tiller arm, the brake, the cross shaft with the bolt for the wheel braces and the double steer wheel all constitute the front of the machine, while the fork and the loading wheels are called the back of the machine.
5. The wheels are generally comprised of one of four materials: steel, nylon, rubber and special plastic derivatives.
6. The weight of the hand pallet truck varies between 60 and 90 kg, with a nominal capacity of 1000 kg to 3000 kg.
7. Some hand pallet trucks have an additional electronic system situated at the front, which gives the operator information about the weight of the load to be transported and may be complemented by a load relief valve in the hydraulic system.

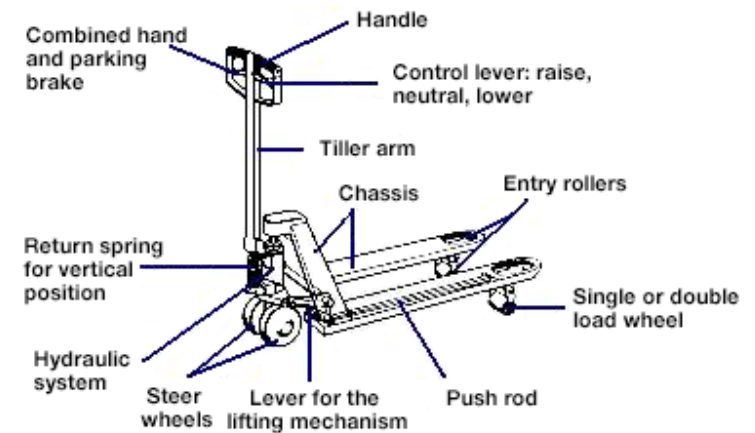

GENERAL RECOMMENDATIONS

1. Do not park a hand pallet truck in a place where it could get in the way of movements.
2. At the end of the working day or after use of the machine, leave it in the parking place assigned to it.
3. A hand pallet truck should be used in places or work areas where the ground is strong enough, even and has no irregularities.



SAFETY AND HYGIENE REGULATIONS



Servei de Prevenció de Riscos Laborals
UNIVERSITAT POLITÈCNICA DE CATALUNYA

HAND PALLET TRUCKS

CODE

SHR 212

Date:

July 2003

Revision:

00

Page:

2 of 3

PERSONAL PROTECTION EQUIPMENT TO USE

Safety footwear: must be anti-slip, with a metal toe cap.



Protecció obligatòria
dels peus



Protecció obligatòria
de les mans

Safety gloves: are not specifically needed to handle the hand pallet truck, but a pair must be available for potential emergencies or for handling other material at work. They should be strong and flexible so that they do not hamper handling of the hand pallet truck.

BEFORE TRANSPORT

1. Check that the weight of the load to be lifted is within the load capacity of the hand pallet truck.
2. Ensure that the pallet or platform is suitable for the load that has to be supported, and that it is in good condition.
3. Ensure that loads are perfectly balanced, steadied and attached to their supports.



DURING TRANSPORT

1. Move the hand pallet truck by pulling on the handle, with the control lever in the neutral position.
2. Move forward by pulling the truck with one hand placed on either the right or left of the machine. Your arm and the tiller arm should be in a straight line while you pull, so there must be enough space free from obstacles to move the pallet truck.
3. Look in the direction in which you are going and make sure you have good visibility all along the route.

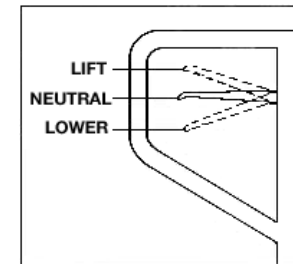

BEFORE TRANSPORT

DURING TRANSPORT

SAFETY AND HYGIENE REGULATIONS



Servei de Prevenció de Riscos Laborals
UNIVERSITAT POLITÈCNICA DE CATALUNYA

HAND PALLET TRUCKS

CODE

SHR 212

Date:

July 2003

Revision:

00

Page:

3 of 3

4. Check that the length of the pallet or platform is longer than the length of the forks. The forks should not jut out as they could damage another load or pallet.
5. Insert the forks into the narrowest part of the pallet as far as they can go under the load. Ensure that both forks are well-centred under the pallet.
6. Avoid lifting the load with just one arm of the fork.

4. If you need to pull the pallet truck backwards, check that there is nothing in the way that could cause an incident.
5. Check the load, particularly when you turn the pallet truck, and monitor its stability, particularly if it is very large.
6. Do not use the hand pallet truck on wet, slippery or uneven ground.
7. Do not handle the pallet truck if you have wet or greasy hands or feet.
8. Only take a hand pallet truck down a slope if it is equipped with a brake. Always stand behind the load when you go down slopes.
9. Before you carry out the manoeuvre of lowering the load, check that there is nothing that could damage or unbalance the load when you place it on the ground.
10. Check that there is nobody nearby who could get trapped by the pallet in the operation of lowering it.

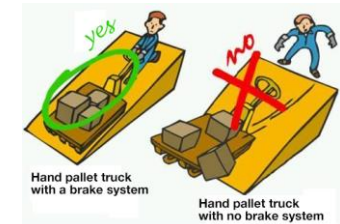

MANTENANCE, ORDER AND CLEANING

1. Follow the manufacturer's guidelines on maintenance of the hydraulic system, tiller bar and wheels.
2. Users of hand pallet trucks who identify a fault should leave the machine with an "out of order" sign and inform the maintenance service so that it can be repaired.
3. The area and places where manual hand trucks are moved should be kept clean to prevent slipping of the trucks or the operators that are handling them.